

E4 Install & Operation Manual



We're online. Chat with us now!



Safety

This appliance can be used by children aged from 8 years and above and persons with reduced physical, sensory or mental capabilities or lack of experience and knowledge if they have been given supervision or instruction concerning use of the appliance in a safe way and understand the hazards involved. Children shall not play with the appliance. Cleaning and user maintenance shall not be made by children without supervision. Cleaning the lens is recommended every 2 weeks. Turn unit off when cleaning. Clean using screen cleaner.

The appliance should be isolated from the electricity supply before removal of any covers. Great care must be employed when working with high pressure carbon dioxide, and in no cases should the maximum operating pressure of 0.4MPa (4 bar) be exceeded.

- The appliance is not suitable for installation in an area where a water jet could be used.
- The appliance shall not be intended for use in lobbies or locations of egress, such as a hallway or public corridor.
- The appliance has to be placed in a horizontal position.

WARNING: Keep ventilation openings in the appliance enclosure or in the built-in structure clear of obstruction.

WARNING: When positioning the appliance, ensure the supply cord is not trapped or damaged.

WARNING: Do not locate multiple portable socket-outlets or portable power supplies at the rear of the appliance.

WARNING: Increased risk of a leak could occur through improper handling, movement or use.

This appliance is intended to be used in household and similar applications such as:-

- Staff kitchen areas in shops, offices and other working environments.
- Farm houses and by clients in hotels, motels and other residential type environments.
- Bed and breakfast type environments.
- Catering and similar non-retail applications.

A-weighted emission sound pressure level is below 70 dB(A).



R290

R290 is a refrigerant-grade propane used on a wide range of commercial refrigeration and air conditioning units. A highly pure propane, it has a low environmental impact and nominal global warming potential (GWP), meaning it possesses no qualities that can destroy the ozone layer. R290 also is the preferred hydrocarbon alternative of the Environmental Protection Agency (EPA), substituting more harmful fluorocarbon refrigerants like R22, R134a, R404a and R502.

Units with R290 can only be maintained and repaired by authorized technicians who are properly trained and certified.



R600a

R600a is a refrigerant-grade propane used on a wide range of commercial refrigeration and air conditioning units. A highly pure propane, it has a low environmental impact and nominal global warming potential (GWP), meaning it possesses no qualities that can destroy the ozone layer. R600a also is the preferred hydrocarbon alternative of the Environmental Protection Agency (EPA), substituting more harmful fluorocarbon refrigerants like R22, R134a, R404a and R502.

Units with R600a can only be maintained and repaired by authorized technicians who are properly trained and certified.

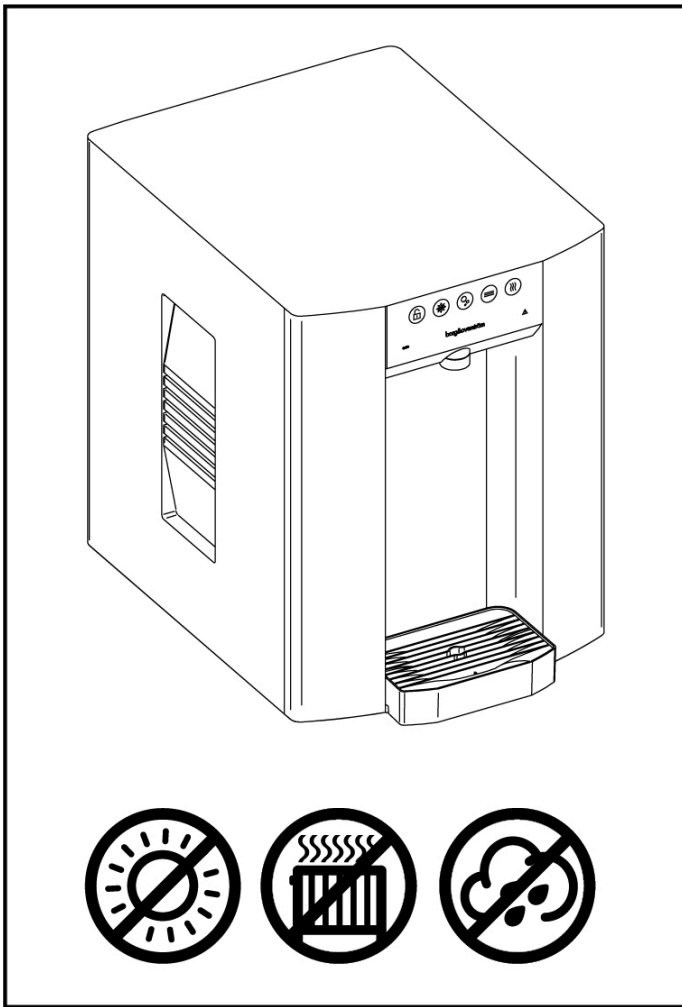

- Always place the dispenser in its vertical position, on a surface which can capably support its weight.
- During use this machine must remain in its upright position.
- Adequate ventilation must be allowed for.
- Keep the machine away from sunlight, heat and moisture.
- Power and water supply points must be available near the dispenser, and must meet the criteria specified in the 'Specification' section of this manual.
- The environment where this machine is installed must be free of dust and corrosive/explosive gases.
- Clean the lens every 2 weeks minimum using screen cleaner – ensure unit is off during cleaning.

Waste Electrical Products:

- The WEEE symbol indicates that this item contains electronic components which must be collected and disposed of separately.
- Never dispose of electrical waste in general municipal waste. Collect and dispose of such waste separately.
- Make use of the return and collection systems available to you, or your local recycling programme. Contact your local authority or place of purchase to find out what schemes are available.
- Electrical and electronic equipment contains hazardous substances which, when disposed of incorrectly, may leak into the ground. This can contribute to soil and water pollution which is hazardous to human health; and endangers wildlife.
- It is essential that consumers look to re-use or recycle electrical or electronic waste to avoid it going to landfill sites or incineration without treatment.



Specification

E4 - 230v

COOLING SYSTEM	Stainless steel direct chill coil encased in a solid-block system for instant response cool down action. Ultra efficiency compression system with capillary control. Environmentally friendly R290 refrigerant.
POWER SUPPLY	230-240v AC (50 Hz)
FUSE RATING	10A
COLD TEMPERATURE FROM	2°C
CHILLED & SPARKLING CAPACITY	50L/h
HOT TEMPERATURE UP TO	92°C
HOT CAPACITY	15L/h
HOT TANK VOLUME	1.5L
MAXIMUM RUNNING POWER CONSUMPTION - CHILLED & AMBIENT	0.11kW-230v
MAXIMUM RUNNING POWER CONSUMPTION - CHILLED, SPARKLING & AMBIENT	0.18kW-230v
MAXIMUM RUNNING POWER CONSUMPTION - CHILLED, AMBIENT & HOT	1.45kW-230v
MAXIMUM RUNNING POWER CONSUMPTION - CHILLED, SPARKLING & HOT	1.55kW-230v
RATED CURRENT - CHILLED & AMBIENT	0.5A
RATED CURRENT - CHILLED, SPARKLING & AMBIENT	0.8A
RATED CURRENT - CHILLED, AMBIENT & HOT	6.4A
RATED CURRENT - CHILLED, SPARKLING & HOT	6.7A
QUANTITY OF REFRIGERATION GAS	R290 33g
WATER CONNECTION	Mains in - 8mm Push Fit
DIMENSIONS	(w x d x h) 320 x 450 x 420mm
WEIGHT - CHILLED & AMBIENT	18Kg

WEIGHT - CHILLED, SPARKLING & AMBIENT	22Kg
WEIGHT - CHILLED, AMBIENT & HOT	20Kg
WEIGHT - CHILLED, SPARKLING & HOT	23.5Kg
MINIMUM TO MAXIMUM INLET WATER PRESSURE	0.05MPa (0.5 bar) - 1.0 MPa (10 bar) Internally regulated to 0.2 MPa (2 bar)
CO2 CONNECTION	1/4" Push Fit
CO2 PRESSURE	0.4MPa (4 Bar) Maximum
MINIMUM TO MAXIMUM AMBIENT ROOM OPERATING TEMPERATURE	5-32°C
CLIMATIC CLASS	N

E4 - 115v

COOLING SYSTEM	Stainless steel direct chill coil encased in a solid-block system for instant response cool down action. Ultra efficiency compression system with capillary control. Environmentally friendly R600a refrigerant.
COLD TEMPERATURE	37°F
CHILLED & SPARKLING CAPACITY	13.2 Gal/h
HOT TEMPERATURE	187°F
HOT CAPACITY	4 Gal/h
MAXIMUM RUNNING POWER CONSUMPTION - CHILLED & AMBIENT	0.11kW - 110V
MAXIMUM RUNNING POWER CONSUMPTION - CHILLED, SPARKLING & AMBIENT	0.16kW - 110V
MAXIMUM RUNNING POWER CONSUMPTION - CHILLED, AMBIENT & HOT	0.82kW - 110V
MAXIMUM RUNNING POWER CONSUMPTION - CHILLED, SPARKLING & HOT	0.91kW - 110V
QUANTITY OF REFRIGERATION GAS	R600a 33g
POWER SUPPLY	110V - 115V AC (50 Hz)
WATER CONNECTION	Mains in - 8mm Push Fit
CO2 CONNECTION	1/4" Push Fit.
DIMENSIONS	(w x d x h) 12.6 x 17.8 x 16.5"
WEIGHT - CHILLED & AMBIENT	39.7lbs
WEIGHT - CHILLED, SPARKLING & AMBIENT	48.5lbs
WEIGHT - CHILLED, AMBIENT & HOT	44.1lbs
WEIGHT - CHILLED, SPARKLING & HOT	51.8lbs
RATED CURRENT - CHILLED & AMBIENT	0.5A
RATED CURRENT - CHILLED, SPARKLING & AMBIENT	1.4A

RATED CURRENT - CHILLED, AMBIENT & HOT	7.4A
RATED CURRENT - CHILLED, SPARKLING & HOT	8.3A
FUSE RATING	10A
MINIMUM TO MAXIMUM INLET WATER PRESSURE	0.05MPa (0.5 bar) - 1.0 MPa (10 bar) Internally regulated to 0.2 MPa (2 bar)
CO2 PRESSURE	0.4MPa (4 Bar) Maximum
MINIMUM TO MAXIMUM AMBIENT ROOM OPERATING TEMPERATURE	41°F - 95°F
CLIMATIC CLASS	N

Model Overview

Introduction

Hygienic and ergonomic, E4 flourishes in all environments – from boardroom to sports hall. Its compact size, large dispense area for bottles, multiple water options and flexible configuration.

The E4 features a flush control panel with no intricate buttons to harbour germs and contaminants, the touch sensitive console delivers instant high-quality chilled, ambient, hot and sparkling water.

Component/Feature Overview

E4 - Major Components

Contents:

- 1 no E4 Unit
- 1 no Power Cord Set

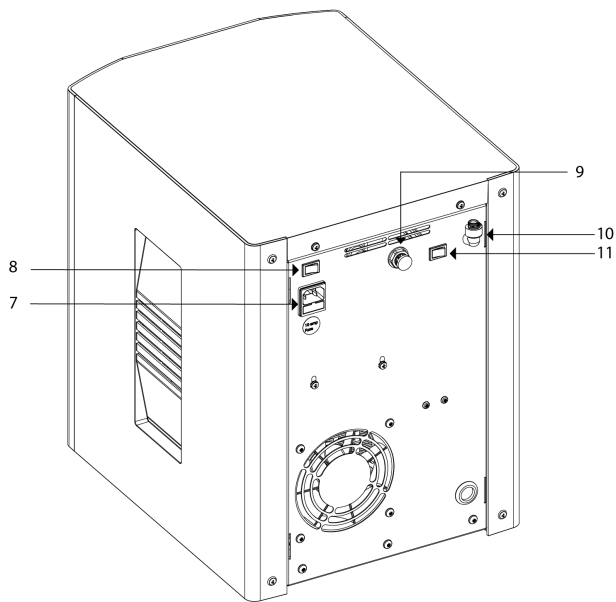
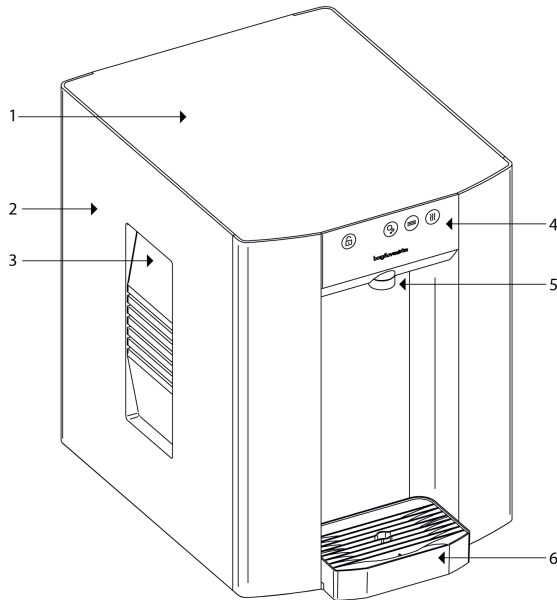

1. Unit Lid, 2. Side Panel, 3. Carry Handle, 4. Control Panel, 5. Dispense Outlet, 6. Drip Tray, 7. Power Connection, 8. On/Off Switch, 9. CO2 Inlet*, 10. Water Inlet, 11. Hot Tank Switch

Please Note:

Mains Installation Kit & Filters are supplied as extra items according to individual ordering requirement.

*Sparkling versions only

Dimensions

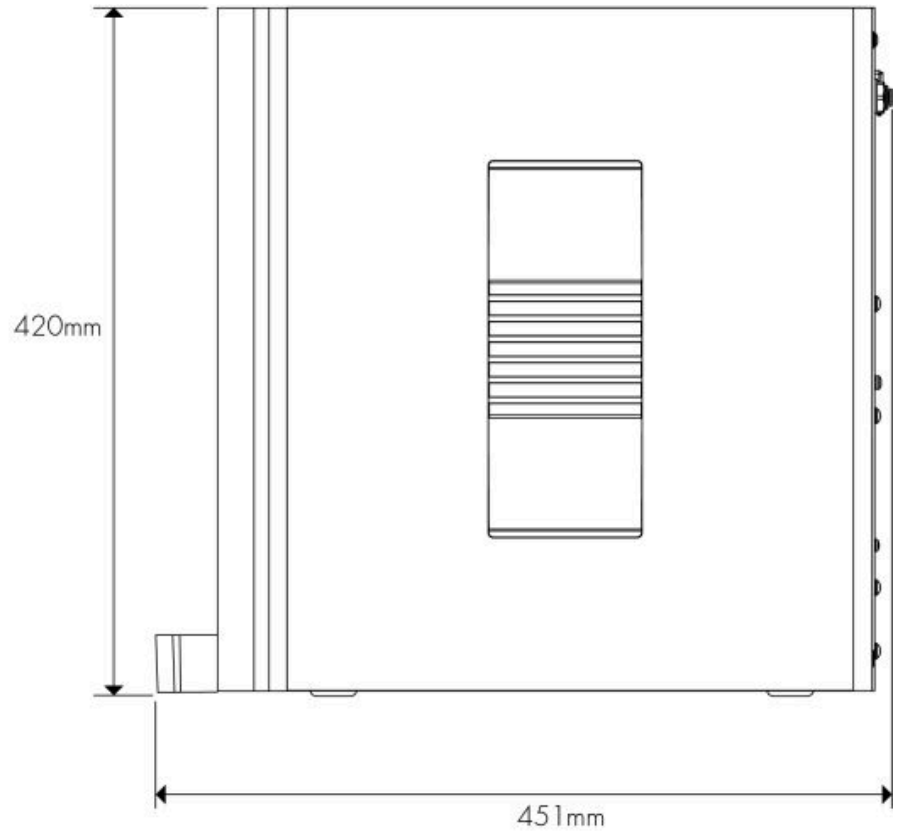
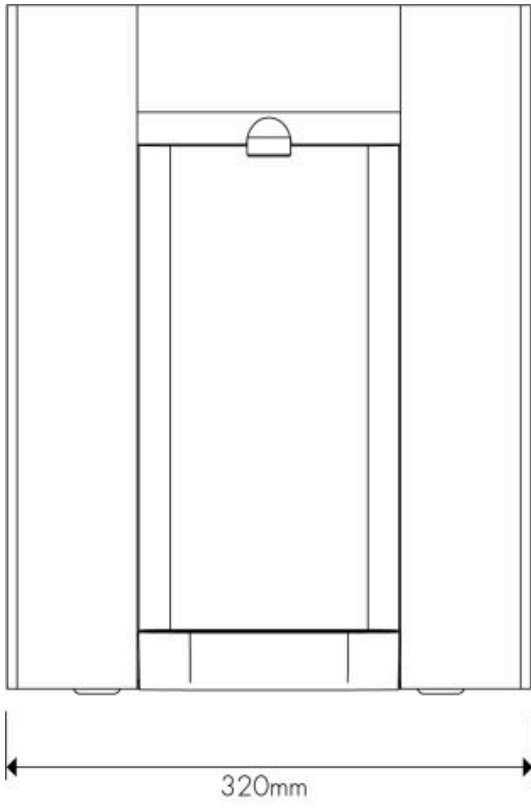

Base Cabinet Dimensions

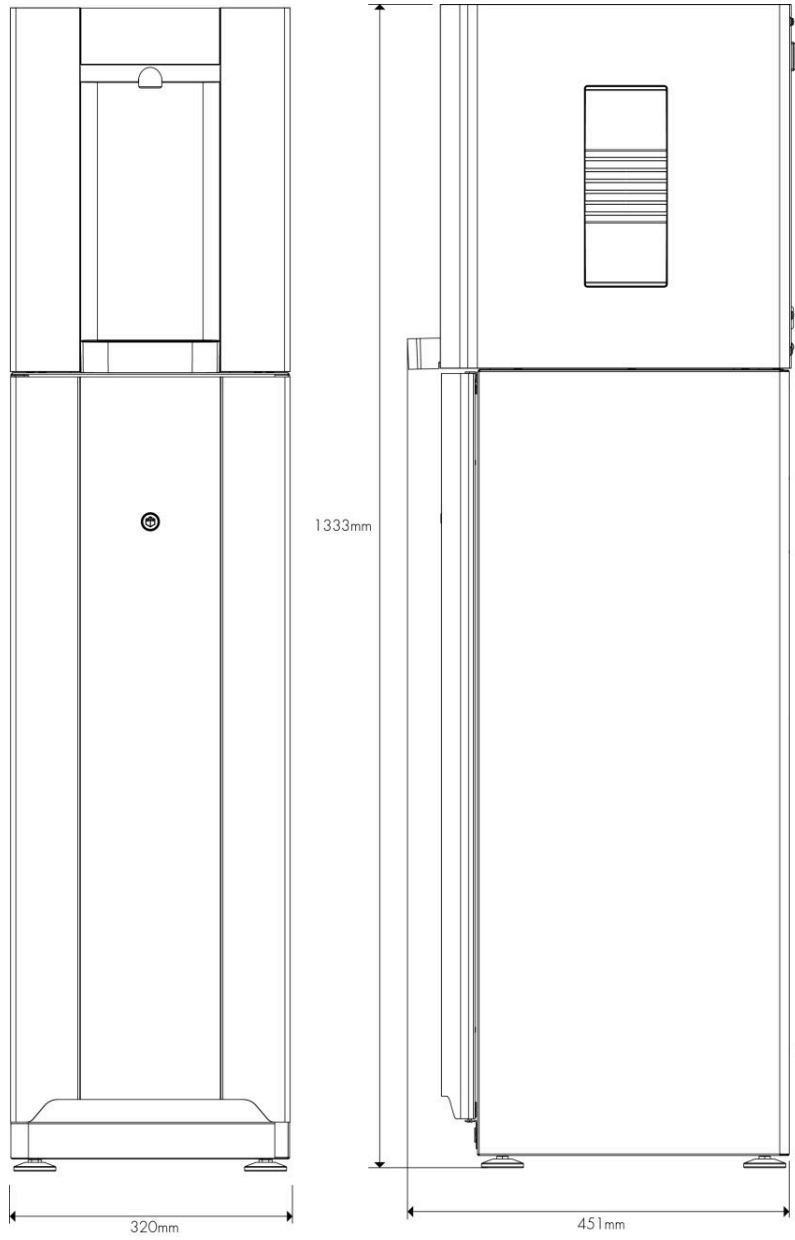

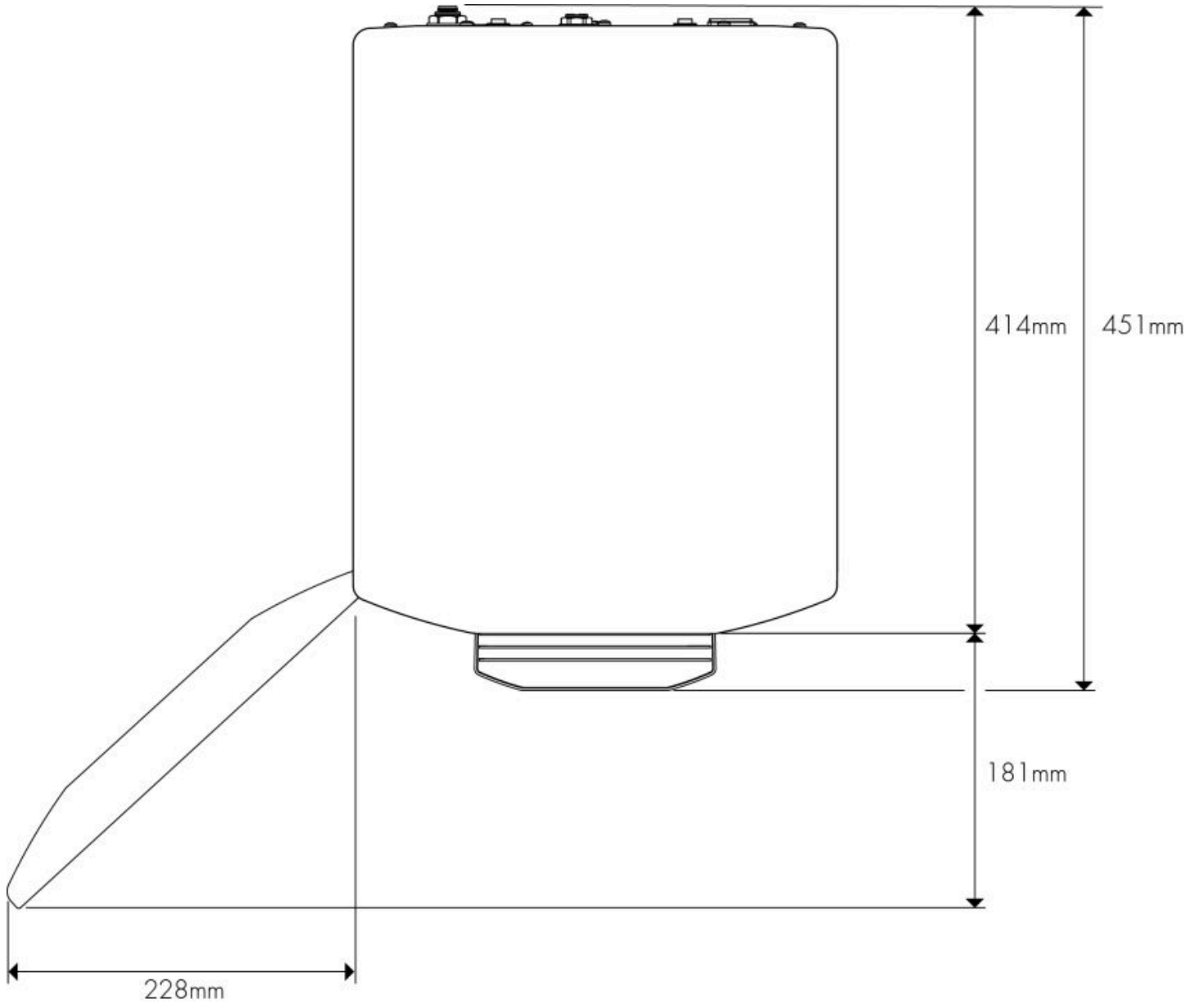

Installation

Installation Requirements

Identify a suitable location for the E4 unit. It should be positioned within 2.0m of suitable services connections. Allow 15cm of free space at the rear for ventilation.

The E4 unit must be installed in accordance with the relevant requirements of:

- The appropriate building regulations by application of either The Building Regulations (England and Wales), The Building Regulations (Scotland) or The Building Regulations (Northern Ireland). In territories other than those listed the local regulations in force must be complied with.
- The Water Supply (Water Fittings) Regulations (England, Wales and Northern Ireland) or The Water Byelaws in Scotland.

The unit must not be installed where it is liable to freeze. If the unit is thought to be frozen it must not be switched on. It should be allowed to thaw and must then be thoroughly inspected to ensure it is undamaged.

Service Requirements

- Water: Mains potable water – internally regulated to 0.2MPa (2 bar)
- CO2: Food Grade CO2 to be supplied
- Min mains pressure 0.05MPa (0.5 bar)
- Electricity: 10A supply – Earth Leakage Protected

Operation

Tap Control Panel

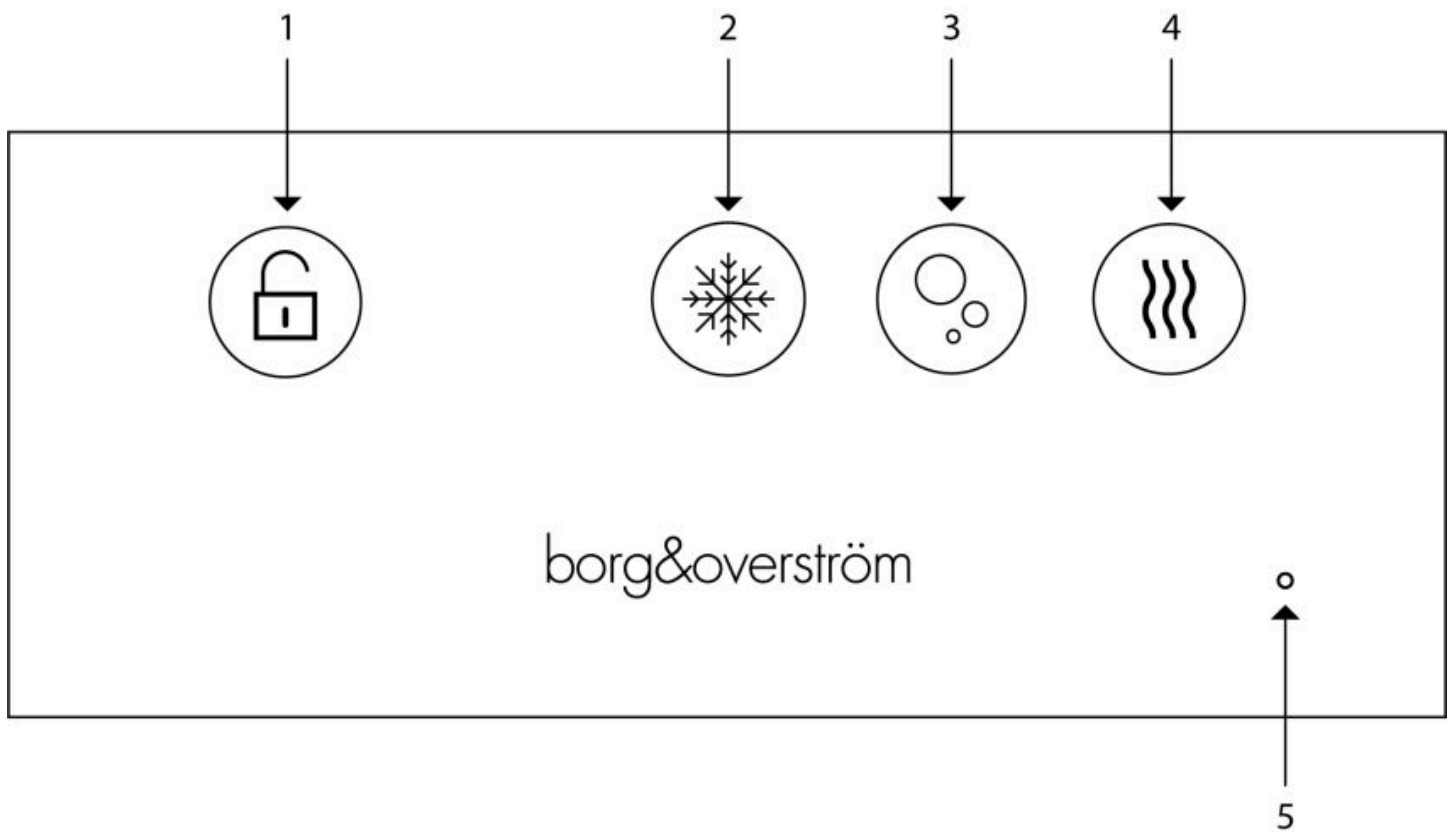

1. Unlock Button, 2. Chilled Dispense, 3. Sparkling Dispense, 4. Hot Dispense, 5. Warning Symbol.

Note: CSH Version shown

Basic Functions

Dispensing cold water from unit:

Press and hold dispense icon and release to finish dispense

Dispensing hot water from unit:

Press the unlock icon and then press and hold the hot button to dispense.

Warning Symbol

'Warning triangle' symbol will illuminate and flash upon a fault. The number of flashes relates to a particular fault. See troubleshoot chapter for more detail.

Connectivity

Bluetooth hands free app dispense

Bluetooth alarmed waste kit enabled

Foot switch operation enabled

E4 Installation & Water Connection

The use of a Borg & Overström installation kit is highly recommended. All kits have been designed to include all the parts you need to safely and correctly install our dispensers. To ensure you select the correct kit for the model you're installing, please visit the website or contact our support team.

All installations of water dispensers must include a water block. A water block is conveniently included in every one of our installation kits. If you're not using Borg & Overström installation kit, ensure you install a water block – failure to do so will negate any insurance claims for water damage resulting from water dispenser malfunction.

For installation kits and water blocks please see our store [here](#).

NOTE: The water filters on the supply line to the unit needs to be pre-flushed prior to the water connection to the appliance.

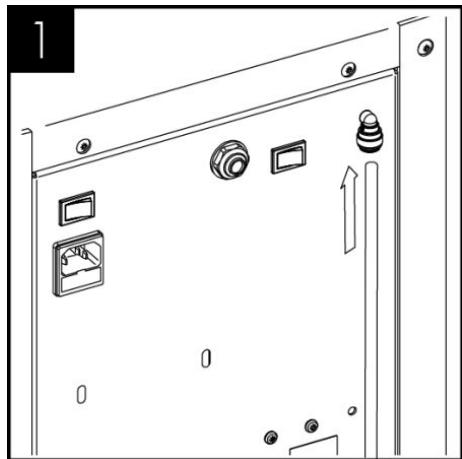

1
Connect to the water supply.

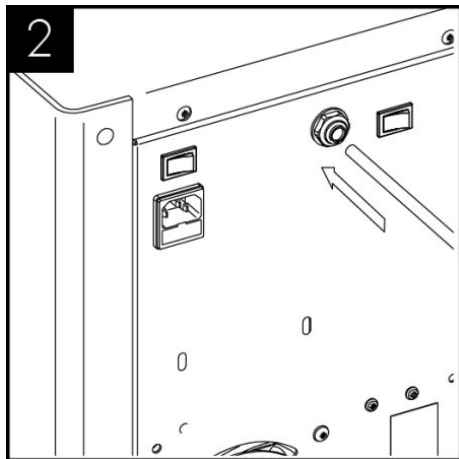

2
Connect the CO2 supply from gas regulator, ensuring the pressure is set to max 58 PSI (4 bar), and turn on the supply (See CO2 Installation section).

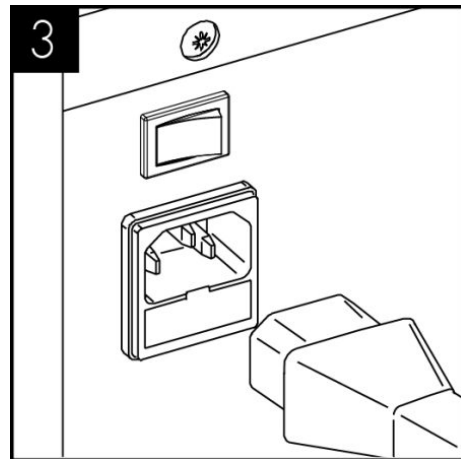

3
Connect the chiller to the electricity supply and ensure unit is switched on.

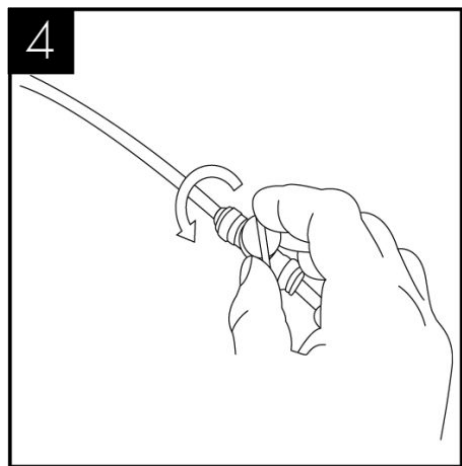

4
Turn on the water supply.

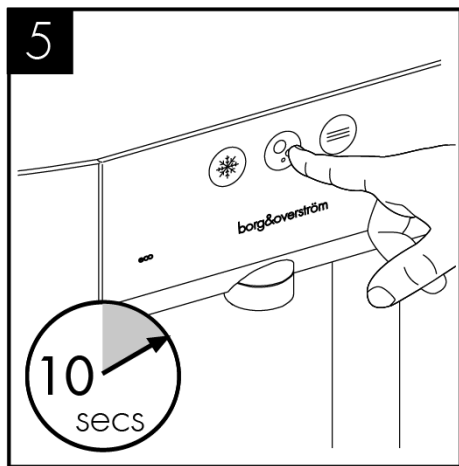

5
The carbonator should be purged of air by activating the sparkling water dispense for approximately 10 seconds.

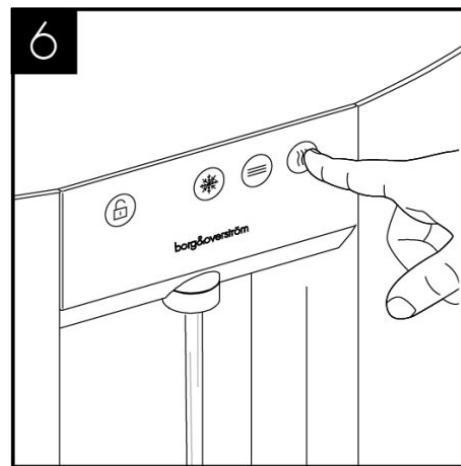

6
The hot versions will have a label below the hot switch on the backplate. Press the unlock icon then hot dispense and wait until you see water flowing from outlet.

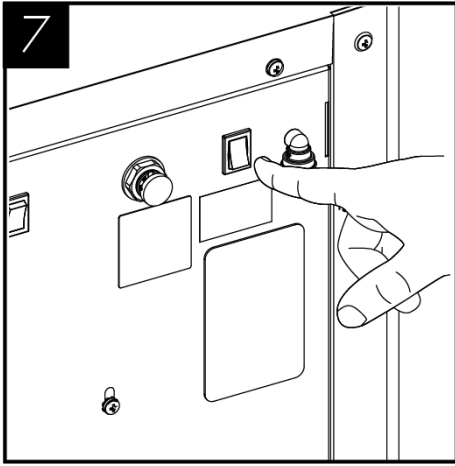

When hot water is dispensing switch the hot switch to 'on'.

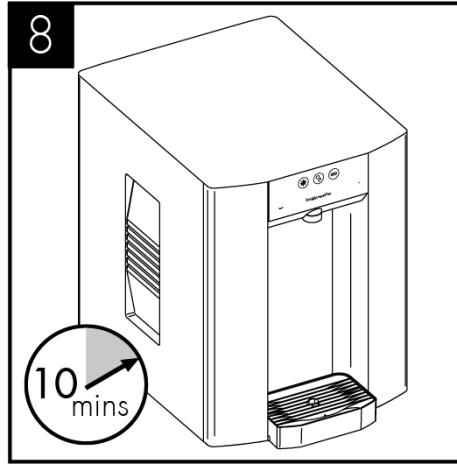

Allow the machine to stand for 8 - 12 minutes for the initial chilling process to complete.

Adding Countertop Drainage

If you require drainage to the driptray when the dispenser is used on a countertop. We recommend you use a hole cutter so your drainage tube can be connected to the mains or to a waste kit in the cupboard below.

Dimensions to help you cut the aperture in the correct position are shown below.

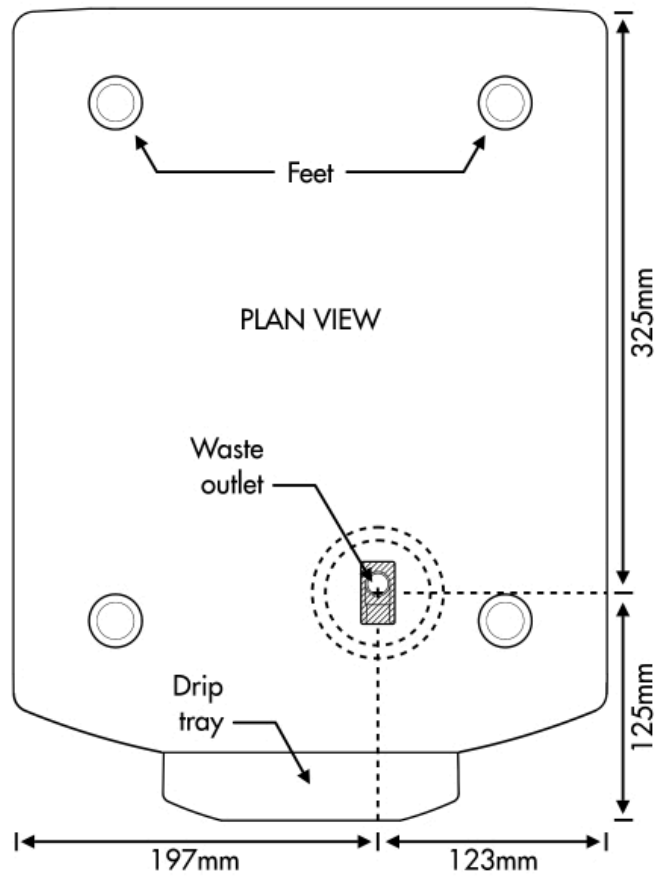

CO2 Bottle Installation - Sparkling Version

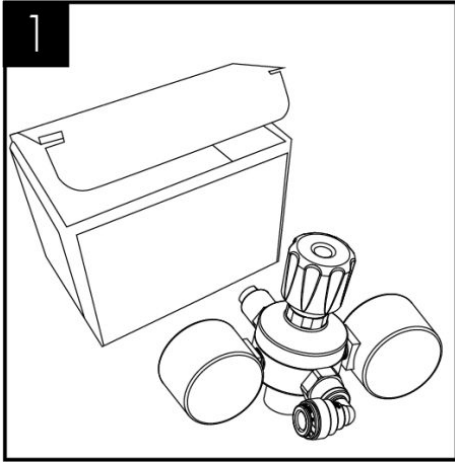

1
Unpack CO2 Regulator and fit elbow fitting to spigot outlet.

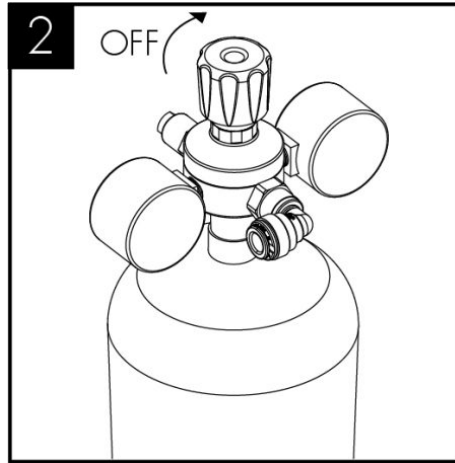

2
Attach the regulator to the disposable CO2 bottle, ensuring the small pressure relief vent in the stem is facing away from you or anyone else. Ensure the regulator is closed. Hand tighten securely.

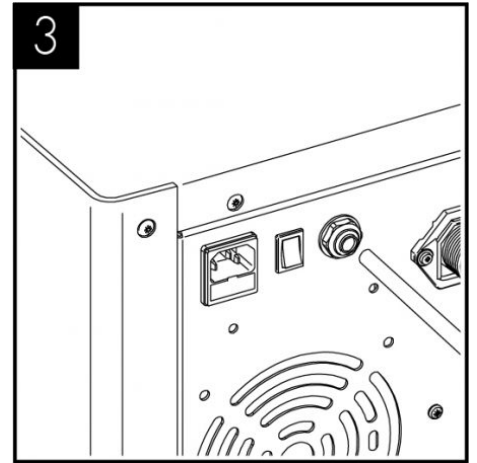

3
Connect the assembled CO2 bottle and regulator to the CO2 inlet using a 1/4" pipe.

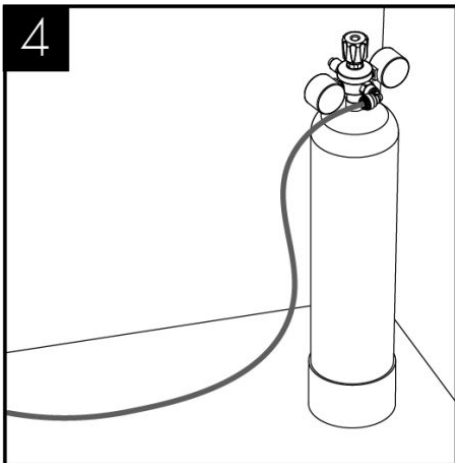

4
Stand the cylinder in a suitable place.

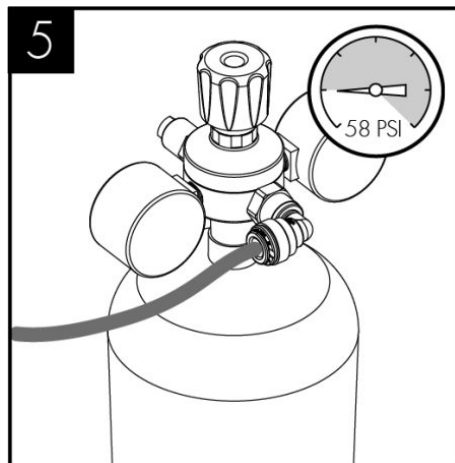

5
We recommend between 3.5 - 4 bar (58 PSI) (max). Do not exceed 4 bar pressure.

Sparkling Water Flow Rate - Sparkling Version

NOTE: Sparkling water flow rate factory setting = 2.4L per minute MAX. This may need adjusting depending on inlet pressure. To do so follow below steps:

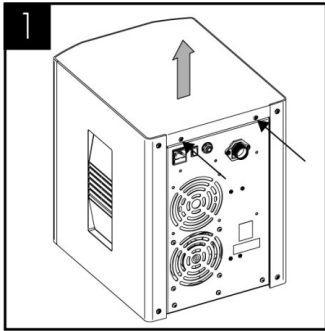

1 Remove the 2 screws holding the unit lid down and slide the lid off.

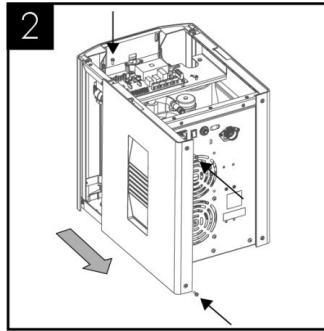

2 Remove the right hand side panel screws. 2 screws are located at the back and one on top. Then slide the panel back to gain access to the flow controller.

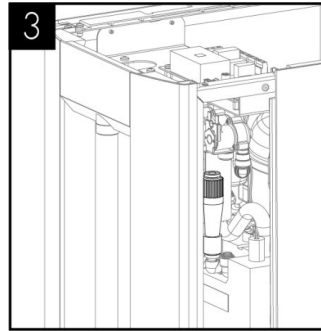

3 Locate the flow control adjuster, this is towards the front of the unit.

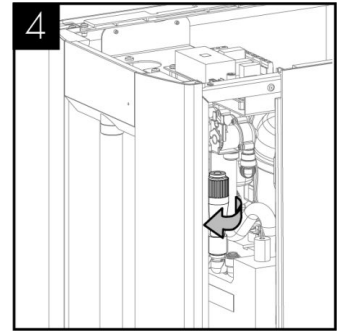

4 Flow can then be adjusted as follows: turning the cap anti-clockwise to increase flow and clockwise to restrict flow. After each adjustment the flow rate should be timed to an acceptable flow rate and/or uninterrupted sparkling dispense.

Once the correct flow rate is achieved place the cover back on to the unit by sliding it in place and replacing the screws.

Hot Tank Commissioning

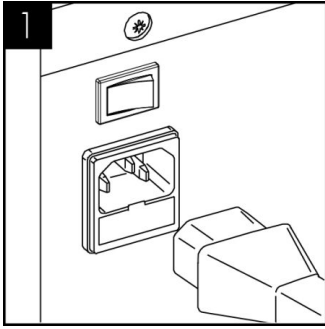

1
Connect the unit to the electricity supply and ensure unit is switched on. Check hot switch is off.

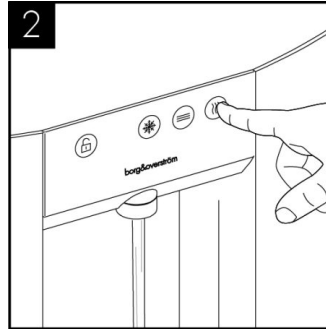

2
The hot versions switch will be off on delivery. Dispense from unit to ensure tank is full.

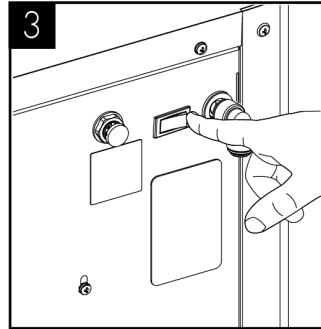

3
Then switch on the hot tank using the hot switch.

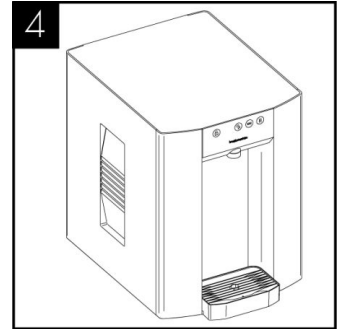

4
Allow the machine to stand for 15 minutes for the initial chilling and heating process to complete.

Maintenance & Cleaning

Sanitisation Guide

The product is supplied from the factory in clean condition, but we recommend that a sanitisation procedure is carried out at the point of installation, according to the sanitisation instruction relevant to this model, which can be found in the respective Instruction & Operation Manual.

NOTE: Failure to use sanitising products and processes approved by Borg & Overström will invalidate your warranty.

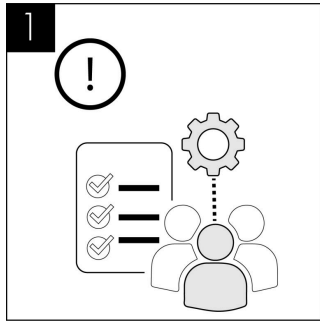

This operation must only be carried out by trained staff.

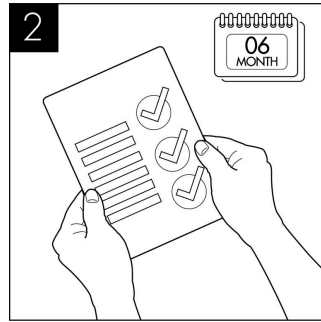

A sanitisation procedure is recommended every 6 months.

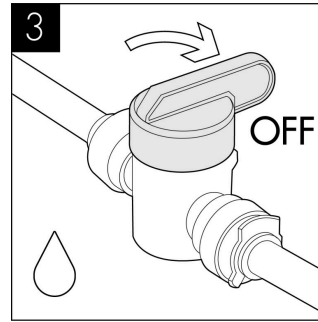

Turn off incoming mains water

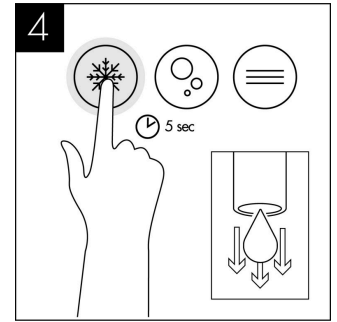

Briefly press chilled dispense button to release internal water pressure from the machine.

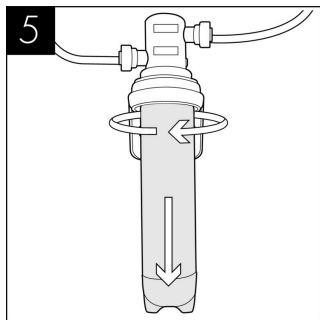

Remove the existing filter

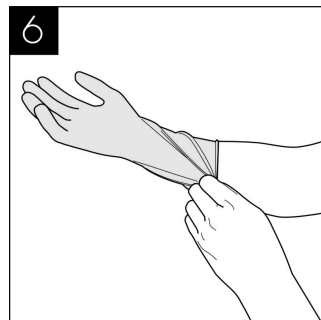

Use hand gel and put on protective gloves.

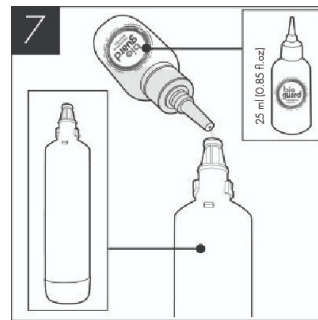

Add 25 ml of Bioguard Internal Sanitising Solution to a clean and empty service filter cartridge.

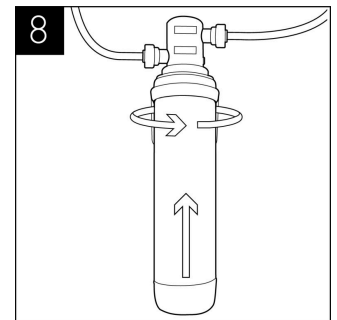

Connect to filter head.

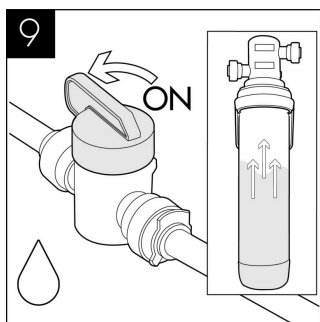

Turn on incoming water, allow the service filter cartridge to fill

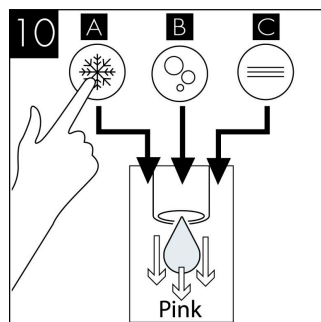

Dispense water using the chilled button until the water appears pink. Repeat with sparkling & ambient water buttons.

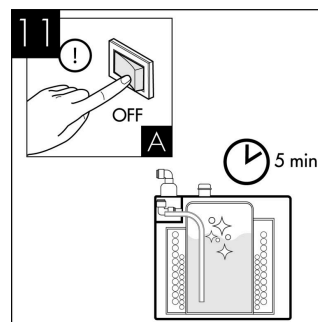

Leave the solution inside machine for sanitisation to take effect (minimum 5 minutes) while thoroughly cleaning the dispenser externally. (All

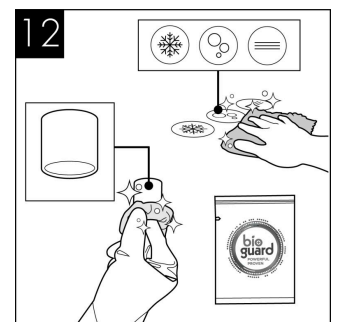

Pay particular attention to the dispense faucet and the push button controls. For this use Sterizen External Sanitiser and Sanitising Wipes.

maintenance operations must be carried out with the dispenser switched off.)

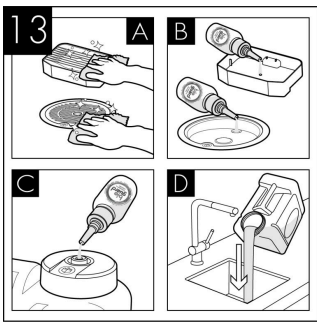

Remember to include the drip tray. If a Waste Overflow System is fitted, empty this and flush through with a small amount of sanitisation fluid if needed.

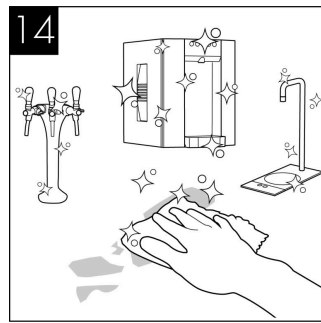

Attend to any cosmetic marks as needed. For this we recommend the use of Bioguard External Sanitiser.

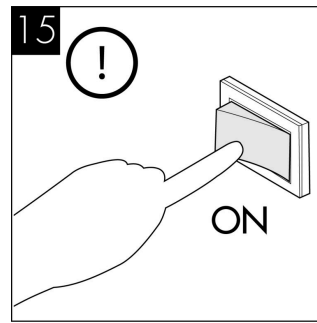

Reconnect the power and switch on the dispenser.

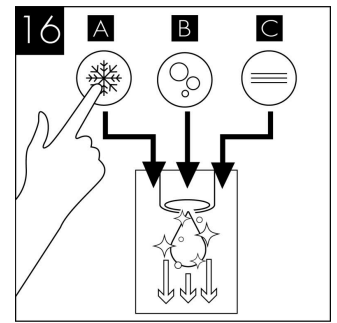

When the external cleaning (minimum 5 minutes) is completed, flush the machine using the chilled button with clean water until the dispense water runs clear. Repeat briefly with the ambient and sparkling buttons if present.

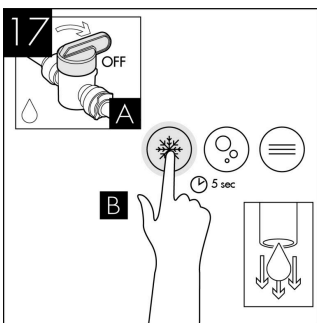

Turn off water and briefly press chilled dispense button to release internal water pressure from the machine.

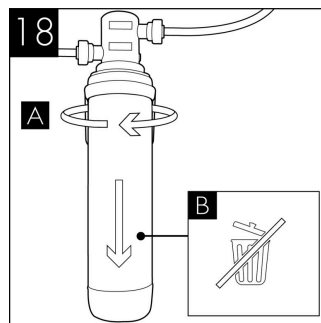

Remove the service filter. Retain service filter for reuse.

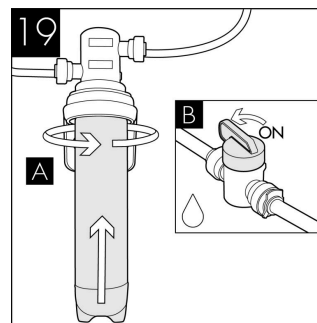

Fit new filter and turn on incoming water supply.

Pre-flush the new filter to waste using the chilled button until the water appears clear and is free of air. Flush through a small amount of water to check all functions.



Please note that this sanitisation fluid contains an active caustic/alkaline agent. Always use responsibly and with care remembering that due to its alkaline nature unnecessary concentrated/prolonged contact with any materials, including metals, can cause damage. Always rinse all contact surfaces after use with clean water.



Avoid skin contact and wear protective gloves when handling sanitisation fluids.



In the event of any skin contact, flush immediately with clean, cold water.

Emptying the CO2 Tank

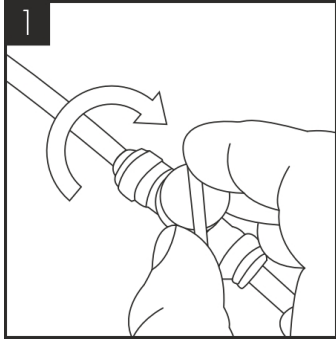

Turn off the water supply.

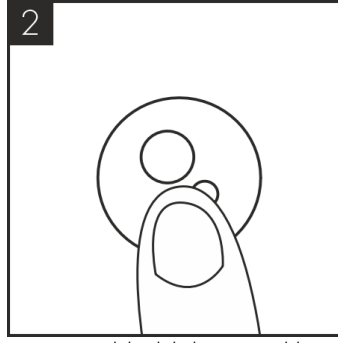

Press and hold the Sparkling water dispense button until all the water is expelled and only CO2 gas is being released.

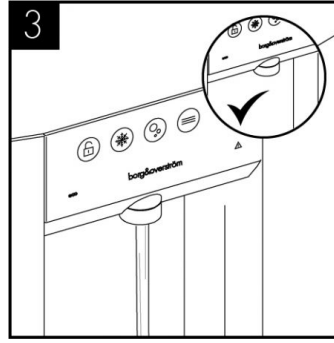

The tank is empty of sparkling water when only CO2 is being released.

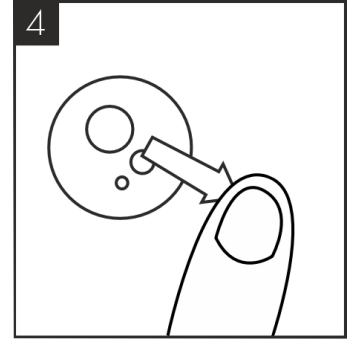

Ensure to release the Sparkling water button and take care to avoid releasing excess amounts of CO2 gas as this may damage the tank.

Advanced Troubleshooting

Fault Diagnostics

Problem/Report	Possible Cause	Suggested Action
No Water Dispensing	Power supply turned off	Check the power supply has been fitted properly and turned on.
	Water pressure regulator	Check water flow through the regulator. Replace if necessary.
	Check tap HMI control	Check fault codes.
	Water isolated from machine	Check water inlet supply.
	Leak detection in unit triggered	Disconnect the power and water supply, check for leaks.
	Lock icon not pressed	To dispense from hot, press the lock symbol first then hot shortly after.
No Sparkling Water	No CO2 pressure	Check CO2 bottle, regulator and non-return valve. Supply pressure should be 58 psi (4bar), replace as necessary.
	Carbonator tank not filling	Check carbonator probe for possible short circuit to ground. Check for pump timeout, cycle power off & on then purge carbonator.
Poor Quality Carbonation	Incorrect CO2 pressure	Check CO2 bottle, regulator and non-return valve. Supply pressure should be 58 psi (4bar), replace as necessary.
	Air in carbonator tank	Refer to installation and water connection section to see how to purge the carbonator tank.
	Residue in carbonator tank	After prolonged use, a surface film can develop within the carbonator tank. Refer to cleaning and sanitising instructions.
Warm Drinks	Insufficient cooling air flow through the fridge	Check that the condenser is not blocked. Check supply to cooling fans. If supply present replace fans. If supply not present move on to the compressor.
	Compressor not running	Check supply to compressor (1 1/2/230V AC). Check NTC probe is not faulty.
	Fridge failure	If compressor & fan are running and there is no cooling contact technical support.

Problem/Report	Possible Cause	Suggested Action
Water lying on top edge of lower door panel and/or bottom of cabinet	Overflowing drip tray or waste container	Empty waste container and check drainpipe is not blocked.
Water lying in bottom of machine	Leak in pipe work and/or filter	Contact your distributor.
Bleeping noise	Level sensor fitted and waste tank full	Empty waste tank.
	Internal leak detect alarm	Check there is no internal leak.
Temperature not hot enough	Mid heating cycle	Unit is not at correct temperature, wait a few minutes before dispensing.
	Power supply turned off	Check the switch is turned on.
	Water demand too high	See product specification.
	Element not working	Check and replace as required.
Dripping	Heater over heating	Ensure a long dispense is carried out to clear any air gaps.
Continuous or incorrect dispense	Poorly seated HMI lens	Replace lens assembly.
	Excess water on lens	Ensure you keep lens clean and clear of liquids.

Fault Codes

Internal leak sensor- including 10 red flashes of dispense area



10 red LED flashes

Carbonator can not filling



Waste kit full



Chilled, Sparkling & Ambient Circuit Schematic

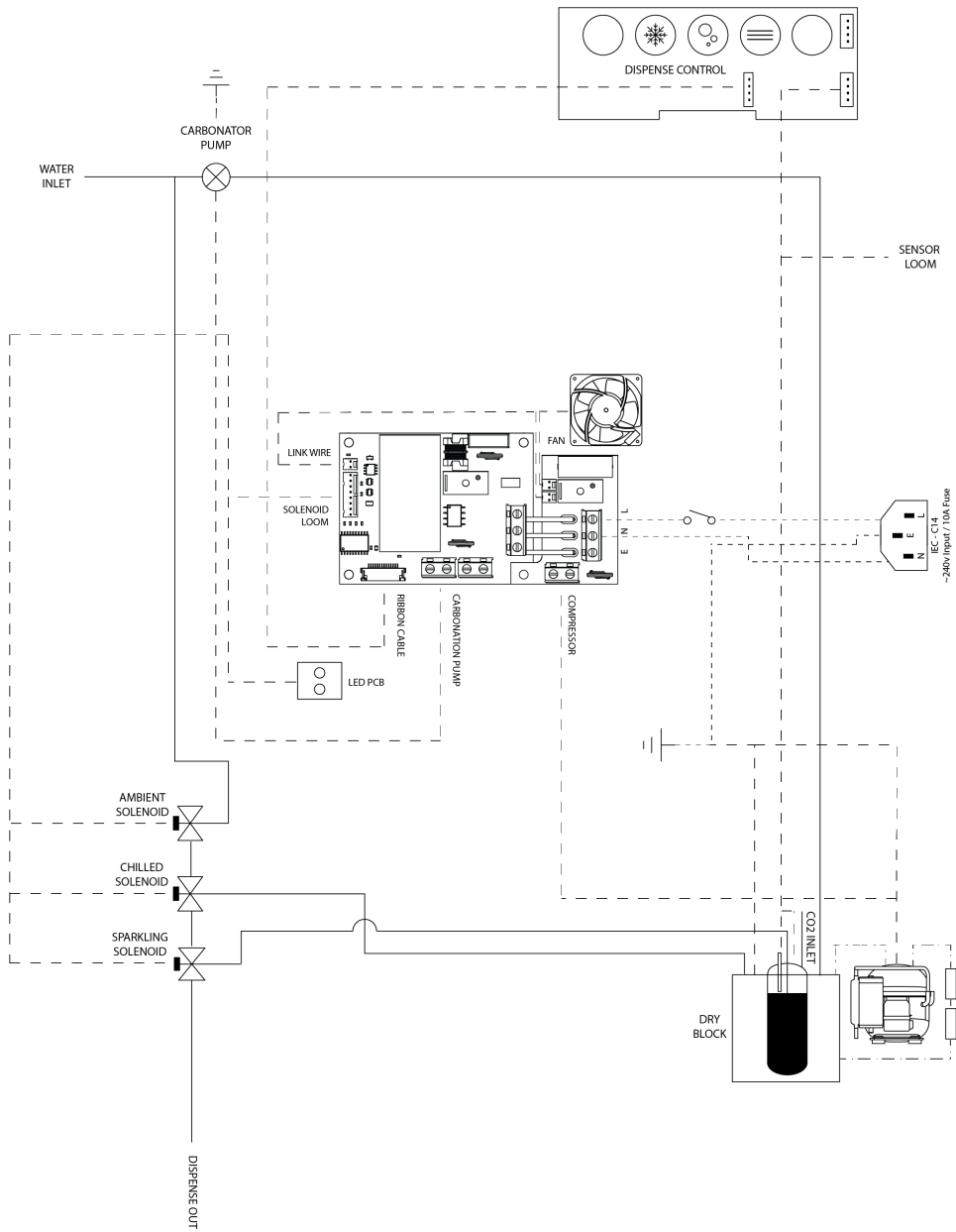

Chilled, Ambient & Hot Circuit Schematic

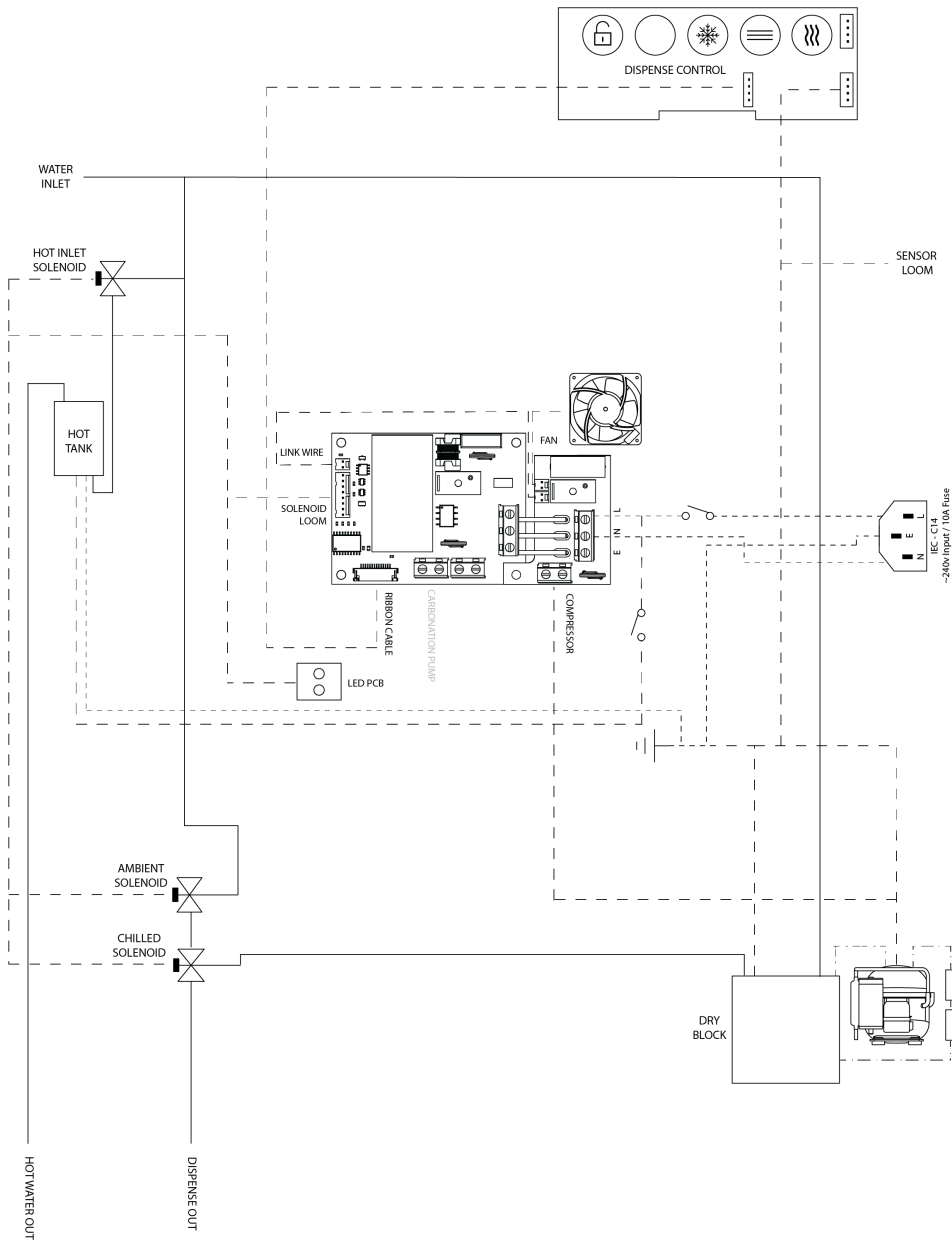

Chilled, Sparkling & Hot Circuit Schematic

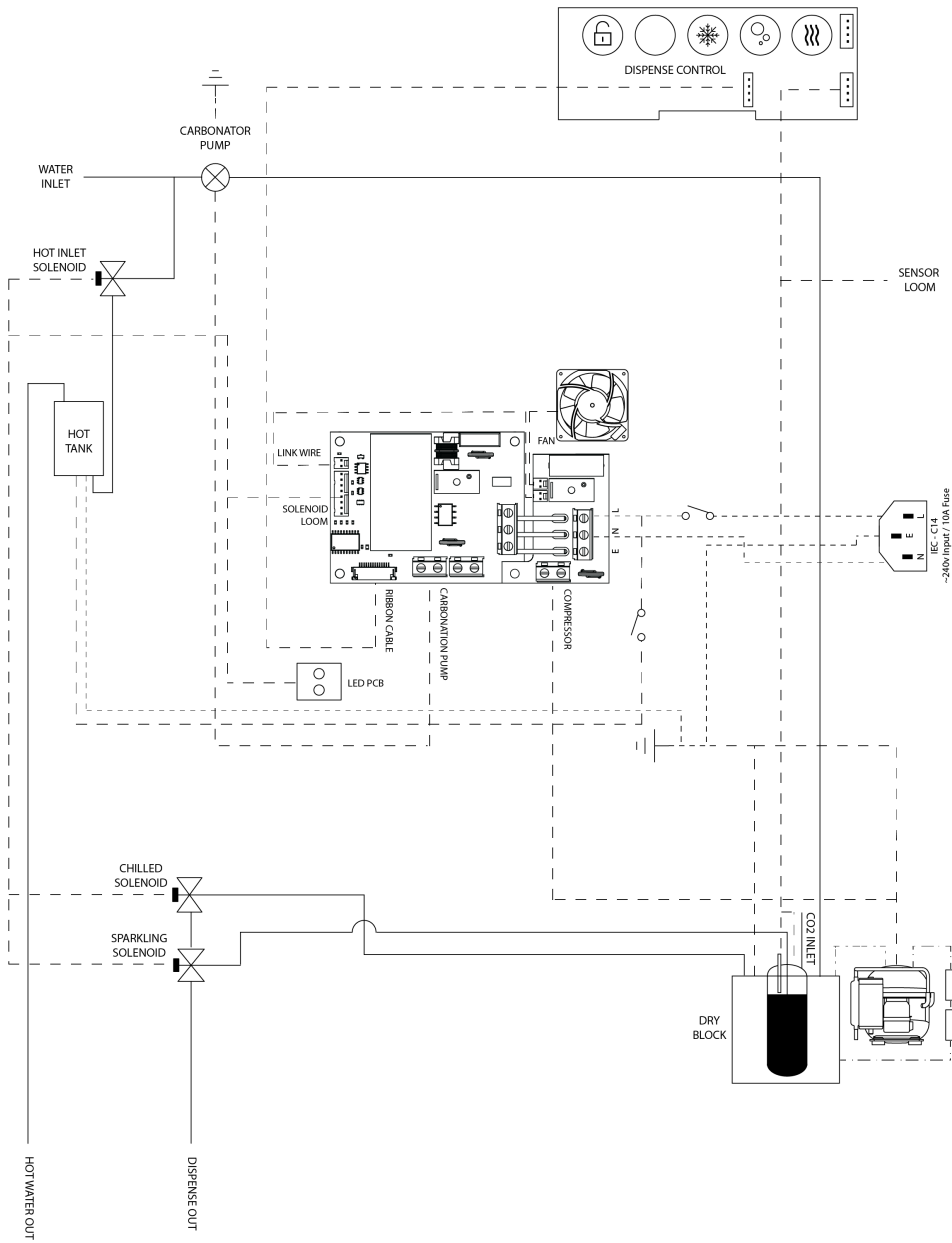

Water Pathway - Chilled & Ambient

Water Pathway - Chilled, Sparkling & Ambient

Water Pathway - Chilled, Ambient & Hot

Water Pathway - Chilled, Sparkling & Hot

Spares

E4 Exploded Parts Diagram

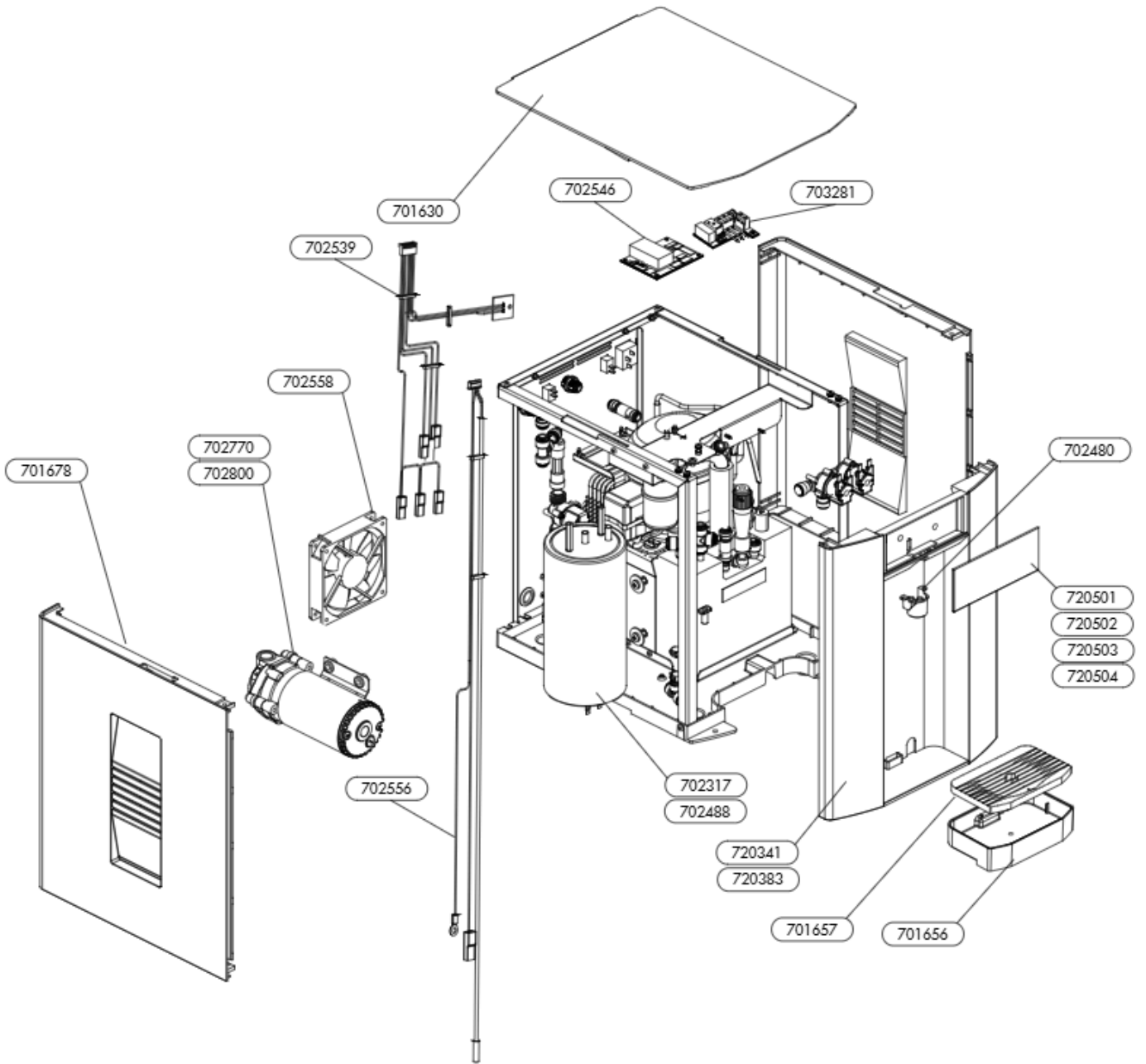

Spares List

Part No.	Description	CA	CAH	CSA	CSH	
702546	Main Control PCBA	•	•	•	•	View in store
703281	Compressor Control Board	•	•	•	•	View in store
701630	Top Panel	•	•	•	•	View in store
701678	Side Panel	•	•	•	•	View in store
720341	Front Panel Black	•	•	•	•	View in store
720383	Front Panel Silver	•	•	•	•	View in store
701656	Drip Tray Black	•	•	•	•	View in store
701657	Drip Tray Font	•	•	•	•	View in store
702558	Cooling Fan	•	•	•	•	View in store
702175	Pump 115v			•	•	View in store
701537	Pump 230v			•	•	View in store
702317	Hot Water Tank 115v		•		•	View in store
702488	Hot Water Tank 230v		•		•	View in store
702418	Cape Washer			•	•	View in store
720501	CA HMI Lens Asm	•				View in store
720502	CAH HMI Lens Asm		•			View in store
720503	CSA HMI Lens Asm			•		View in store
720504	CSH HMI Lens Asm				•	View in store
702480	Outlet	•	•	•	•	View in store
720023	Temperature Probe		•		•	View in store
702556	Sensor Loom E4	•	•	•	•	View in store
702539	Solenoid Loom E4	•	•	•	•	View in store
Part No.	Description	CA	CAH	CSA	CSH	
701886	8mm PRV 2 Bar	•	•	•	•	View in store
701729	Hot Inlet Solenoid		•		•	View in store
701937	8mm 2 Way Solenoid	•	•		•	View in store

Part No.	Description	CA	CAH	CSA	CSH	
701992	8mm 3 Way Solenoid			•		View in store
637329	8mm Compensator			•	•	View in store
462667	8mm Safety Check Valve			•	•	View in store
462668	1/4" Safety Check Valve			•	•	View in store
702146	Hot Flow Restrictor		•		•	View in store